



tile & stone
Installation Systems

ARDEX Products Assembly

1. Grout Options:

- A. ARDEX WA™ Epoxy Grout and Adhesive
- B. ARDEX FL™ Rapid Set, Flexible Sanded Grout
- C. ARDEX FG-C™ MICROTEC® Unsanded Grout

2. Latex-Portland Cement Options:

- A. ARDEX X 77™ MICROTEC® Fiber Reinforced Thin Set Mortar
- B. ARDEX X 32™ MICROTEC® Fiber Reinforced Rapid Setting Thin-to-Thick Bed Mortar
- C. ARDEX X 78™ MICROTEC® Premium Semipourable Thin Set Mortar
- D. ARDEX X 5™ Flexible Thin Set Mortar

3. Sound Control / Crack-Isolation Membrane:

- A. ARDEX D 70™ Sound Deadening Mat with ARDEX AF 207™ Pre-Mixed, Rapid Set Schlüter® DITRA Bonding Adhesive

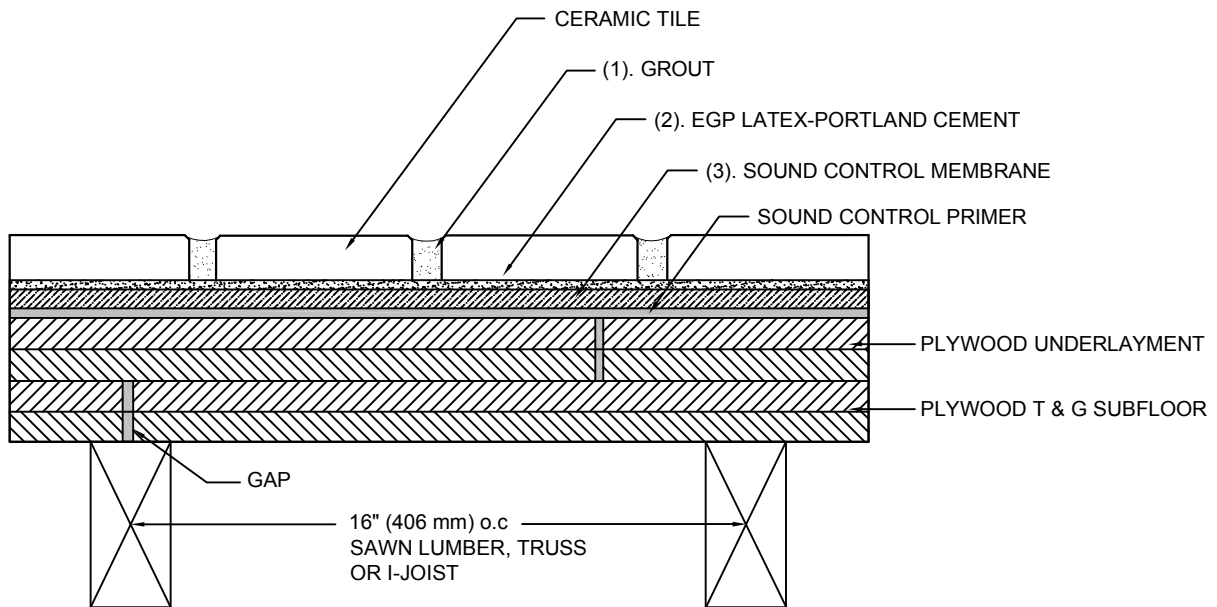

Scale: N.T.S.

Drawings are developed to be compatible with Tile Council of North America 2013 TCNA Handbook for Ceramic, Glass and Stone Tile Installation.

ARDEX products are listed as options and are substituted for TCA's and TTMAC's listed ANSI and ISO 13007 standards. Please refer to the Tile Council of North America 2013 TCNA Handbook for Ceramic, Glass and Stone Tile Installation for complete instructions and application limitations.

Some installation methods and component materials are not referenced. ARDEX Americas encourages the user to consult all approved resources to ensure a complete assembly.

ARDEX Americas
400 Ardex Park Drive
Aliquippa, PA 15001

Technical Services:
1-800-512-7339
www.ardexamericas.com



Floors, Interior

Wood Subfloor, Sound Control
Latex-Portland Cement Mortar

AF150SC
TCNA: F150 Modified
TTMAC: 313F-SC