



ARDEX Products Assembly

1. Grout Options:

- A. ARDEX FL™ Rapid Set, Flexible, Sanded Grout
- B. ARDEX FH™ Sanded Floor and Wall Grout
- C. ARDEX WA™ High Performance, 100% Solids Epoxy Grout and Adhesive

2. Portland Cement Mortar:

- A. ARDEX X 77™ MICROTEC® Fiber Reinforced Tile and Stone Mortar
- B. ARDEX X 78™ MICROTEC® Semi-Pourable Tile and Stone Mortar
- C. ARDEX S 28™ MICROTEC® Rapid Set, Rapid Dry Super Format Tile and Uncoupling Membrane Mortar

3. Uncoupling Membrane

- A. ARDEX UI 720™ FLEXBONE® Floating Uncoupling Membrane

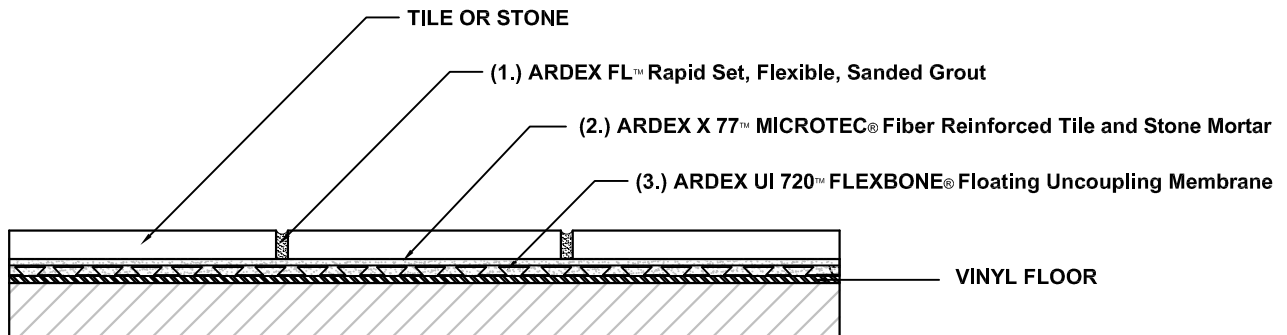

Scale: N.T.S.

Drawings are developed to be compatible with Tile Council of North America 2013 TCNA Handbook for Ceramic, Glass and Stone Tile Installation.

ARDEX products are listed as options and are substituted for TCA's and TTMAC's listed ANSI and ISO 13007 standards. Please refer to the Tile Council of North America 2013 TCNA Handbook for Ceramic, Glass and Stone Tile Installation for complete instructions and application limitations.

Some installation methods and component materials are not referenced. ARDEX Americas encourages the user to consult all approved resources to ensure a complete assembly.

ARDEX Americas
400 Ardex Park Drive
Aliquippa, PA 15001

Technical Services:
1-800-512-7339
www.ardexamericas.com



Floors, Interior

Vinyl Floor, Uncoupling Membrane

AF186
TCNA: F128
TTMAC: 311F-D